

The Caribbean Steelpan, and some Offsprings

Uwe J. Hansen

Indiana State University, Terre Haute, IN 47809, USA, u-hansen@indstate.edu

Thomas D. Rossing

Northern Illinois University, DeKalb, IL 60115, USA, rossing@physics.niu.edu

Mode studies by a number of researchers in musical acoustics has had some influence on the tuning of individual note sections of this instrument, which is likely the most significant new acoustic, as opposed to electronic, musical instrument of the twentieth century. Operational deflection shapes of individual note sections along with coupling between note sections lead to the characteristic “steel” sound. Usually the lowest three partials are tuned in octaves and twelfth or double octaves. Some interesting examples of mode shapes and coupling will be discussed. One Pan Crafter in Switzerland has used insights from such research to develop a new family of instruments, which he calls the Ping, Peng and Pong. Furthermore he incorporated the new note section structure in a hand-held instrument, he calls the Hang. Examples of the mode structures of these instruments will be shown and discussed.

1 Introduction

The Steelpan is likely the most significant new acoustic, as opposed to electronic, musical instrument of the twentieth century. Originating from a folk tradition in the Caribbean, it has spread throughout the Americas and to Europe. There is hardly a percussion program in an American university music department without a steel band. Usually a lead pan spans 2 ½ octaves, while two pans span the range of a double second instrument, and as many as six pans are often used for a bass instrument. Originally pans were crafted from discarded 55 gallon oil drums. The top, with its filling holes, was cut off, and the drum bottom was processed into the playing surface. One of the reasons for the skirt is to avoid short circuiting sound pressure fields with a 180° phase difference between front and back. For short wavelengths, i. e. high frequencies of tenor pans, a short skirt is adequate, whereas bass pans usually retain almost the entire length of the drum side panel for the skirt. The pan surface is hammered into the shape of a spherical segment, with the depth determined by the pitch register of the intended instrument. A lead tenor is sunk to a significantly greater depth than lower pitched instruments, with bass pans remaining nearly flat. Boundaries for individual note sections are usually established with round chisel marks. Clearly, size is a principal pitch determining factor. Fine-tuning is accomplished by imposing a reverse curvature on the individual note section, along with selective hammering from the back to shift overtones relative to each other to impose harmonicity. In most cases, at

least three partials are tuned harmonically [1, 2,]. Note arrangement usually follows a circle of fifths and fourths with the middle circle following the outer note circle in octaves, and the inner circle in turn following with the first five notes of the chromatic scale in a third octave (see Figure 1.)

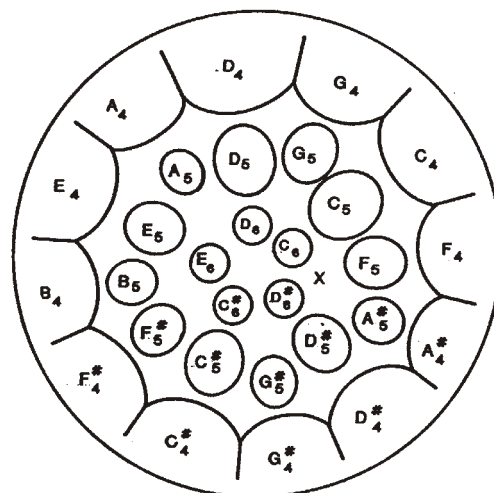

Figure 1: Note layout for a lead tenor pan by “Pan Art”

2 Pan Characteristics

2.1 Nonlinear Behavior

The steelpan is inherently a nonlinear instrument, consequently, impacts with increased force do not merely cause a proportionate spectral amplitude increase, but rather excite additional spectral components. This is shown in Figure 2.

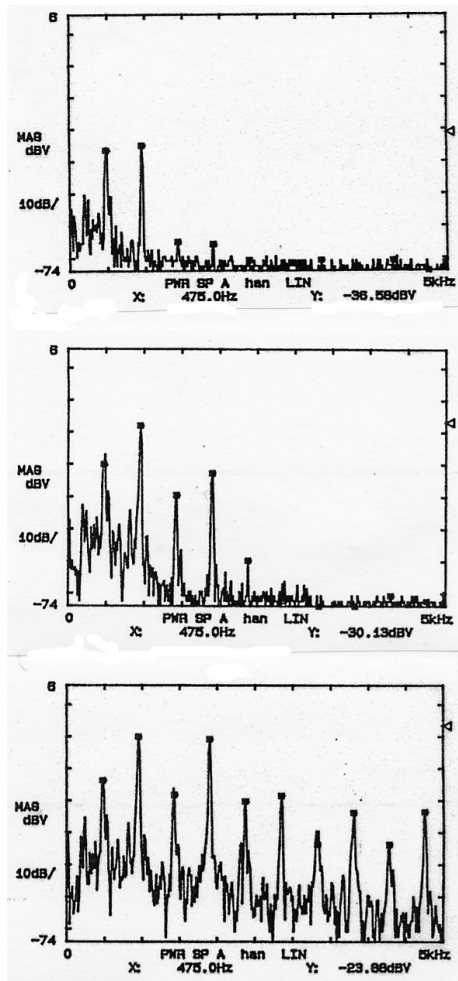

Figure 2: Sound spectra of $A_4^\#$ note section of PanArt lead Tenor Pan with mallet blow near the front of the section top: soft-; middle: medium-; bottom: hard blow

This spectral change with change in impact force is clearly discernable during pan concert performances.

The tone color of the instrument is noticeably dependent on the intensity of performance.

2.2 Tuning

As mentioned earlier, skilled tuners are able to routinely adjust the tuning of partials to bring at least the lowest three partials into nearly harmonic relationships. This is accomplished by selective hammering in each note section. Clearly, modifying the stiffness, thickness or curvature along a nodal line for a mode associated with a particular partial will have little effect on the resonance frequency of that mode, since there is little or no motion or bending at the nodal line for that mode. The frequencies of other partials, however, will be shifted by such changes. Thus a skilled craftsman, with knowledge of the mode patterns, will be able to shift the partial frequencies relative to each other to bring them into harmonic relationships. Mode shapes of individual note sections are observed by electronic holographic interferometry. While standard optical holography is very time consuming, this process permits mode observation nearly in real time. The pan is supported as indicated in Figure 3, and the interferograms are recorded with a ccd camera as outlined in the block diagram of Figure 4. Figure 5 shows the mode shapes of the first three partials of a G_3 note section of a “PanArt” tenor pan..

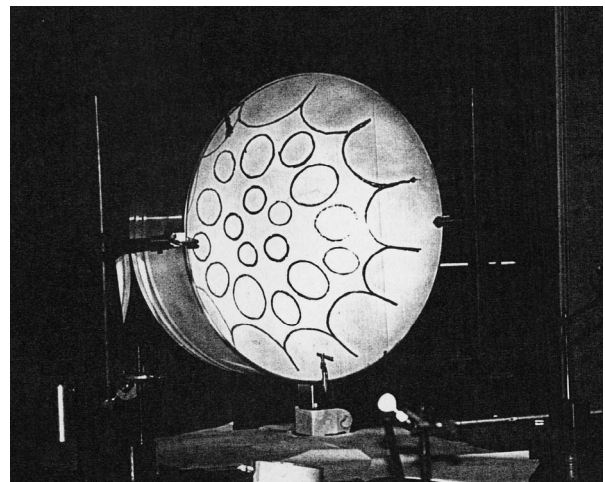

Figure 3: “PanArt” lead tenor pan Mounted for holographic imaging

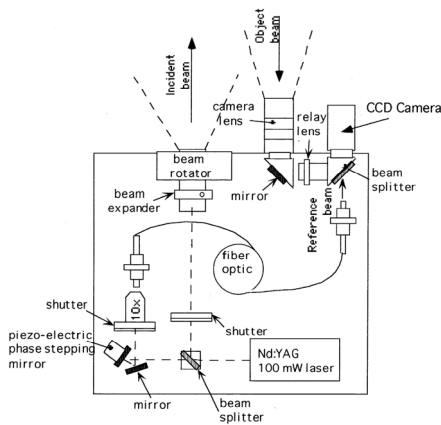

Figure 4: Instrumentation for electronic holographic interferometry.

2.3 Mode Coupling

Inasmuch as all note sections are imbedded in the same steel matrix, it is inevitable that excitation of one note section will result in some level of response in other, if not all sections. A number of circumstances will lead to such coupling. Most prominent among these is the presence of partials of the same frequency in different note sections. Thus, arranging adjacent notes with an interval of a fifth, and the second circle an octave above that, and tuning the lowest three partials in a 1:2:3 frequency relationship, i.e. as an octave and a fifth, leads to the fact that the fundamental of the middle circle G_5 has a frequency of 831 Hz, which coincides with the second partial of the adjacent G_4 note section in the outer circle, and also with the third partial of the C_4 . This is illustrated in Figure 8. The skirt also has a resonant mode at nearly the same frequency as shown in Figure 9.

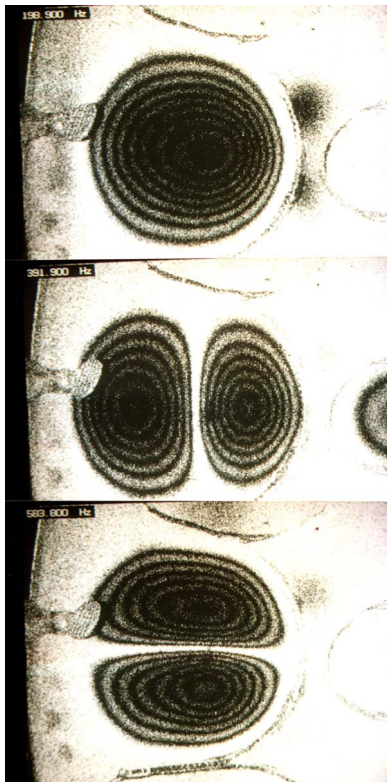

Figure 5: The lowest three partials of a G_3 note sections at 198.9 Hz, 391.9 Hz, and 583.8 Hz (from top to bottom)

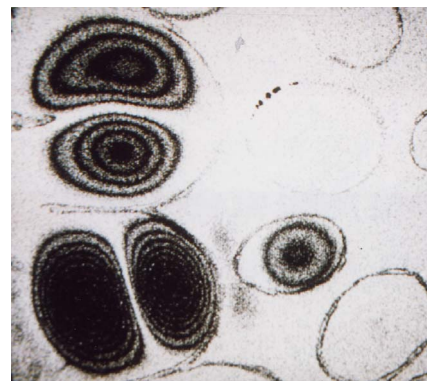

Figure 8: Mode coupling in G_5 (small right bottom), G_4 (lower left), and C_4 (upper left) note sections

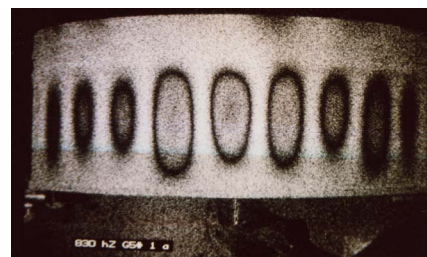

Figure 9: Skirt mode at 830 Hz. (the pan playing surface is at the bottom)

Additional mode coupling relies heavily on non-linear contributions resulting from additional spectral components at frequencies other than the drive frequency. This is shown in an Cliff Alexis double second pan driven at the frequency of the second partial of the D₄ note section at 864 Hz.. The four images represent the global response pattern of the entire pan when the drive current is increased from 1 A to 4 A in 1 Ampere steps (Figure 10)

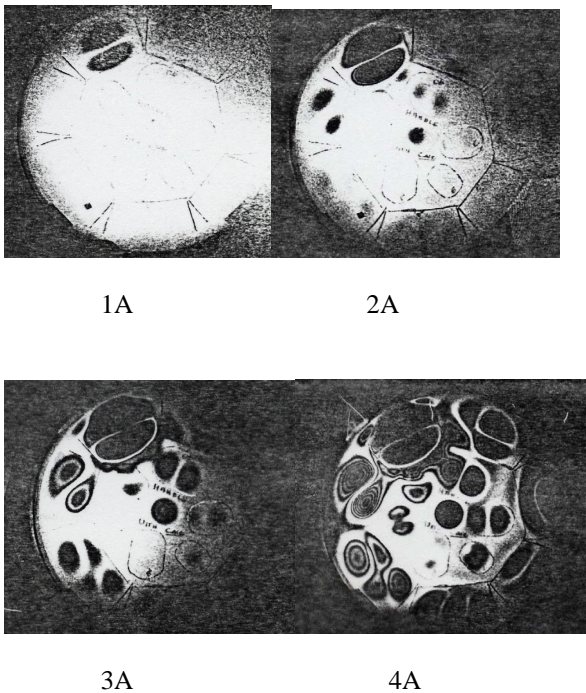

Figure 10: Second mode of a D₄ note section of a double second pan, driven with increasing amplitude.

3 New Developments

3.1 Pan Fabrication: The Press

A limitation of the folk art of pan crafting lies in the raw material. Discarded commercial steel drums are not very uniform, furthermore, sinking the pan by hand does not lead to a very uniform product. Several pan crafters risk incurring the wrath of the Caribbean steel community by sinking the pan mechanically. This is accomplished by using fresh rolled sheet steel,

impressing the spherical curvature in a mechanical press and affixing the skirt afterwards. This provides the opportunity to optimize material choices with regards to alloy content and thickness. It also results in a reproducibly uniform product. Subsequent tuning can be accomplished more easily and more precisely. One artisan, Felix Rohner of PanArt in Switzerland, compares the sinking of the pan to the artist's preparation of the canvas, and the tuning to the work of art. Figure 11 outlines the steps of press sinking and affixing the skirt.

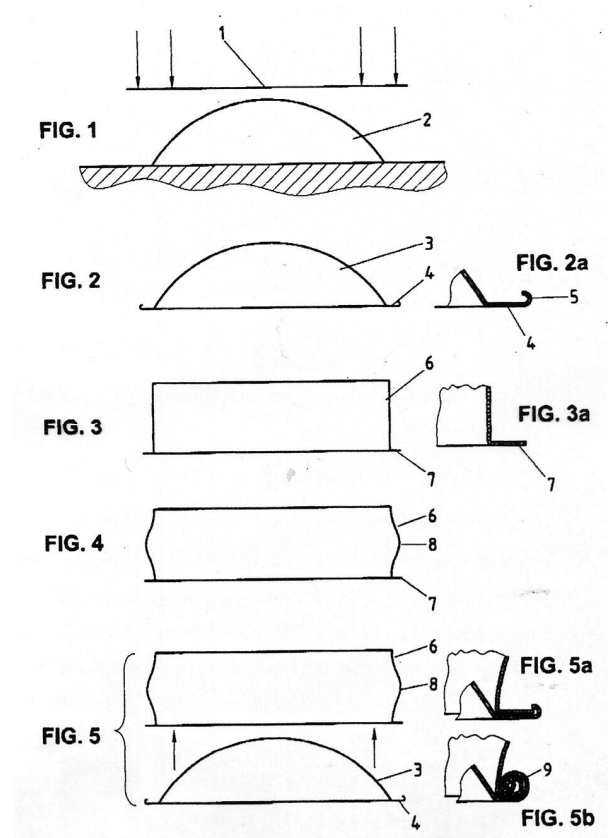

Figure 11: Steps in mechanical pan preparation (courtesy Felix Rohner of PanArt)

- Step 1: Press sinking sheet metal (FIG. 1)
- Step 2: Preparing edge to receive skirt (FIG. 2)
- Step 3: Preparing skirt edge (FIG. 3)
- Step 4: Shaping Skirt (FIG. 4)
- Step 5: Affixing skirt to pan blank (FIG. 5)

3.2 Pan Layout

Note sections in traditional Caribbean steelpan are delineated by an overlapping line of circular chisel marks. These marks serve two purposes. Physically they serve as a reflection boundary for the bending waves traveling as transverse two dimensional waves over the note section surface. The imposition of these boundary conditions enable the formation of standing waves which form the vibrational modes of the note sections. They also assist the performer in locating the individual note sections. The tuning process leaves individual note sections either relatively flat in the spherical curvature of the sunken pan, or in many cases with a curvature opposite the basic pan curvature. In either case, a relatively narrow region of sharp curvature change surrounds each note section. This narrow region with a rather short radius of curvature serves itself as a reflecting boundary, which obviates the need for chisel marks. PanArt consequently dispenses with the tedious procedure of using chisel marks to delineate note areas. Analytically this complicates the Eigenvalue problem with a fuzzy boundary, but acoustically the overall result is very satisfying.

3.3 Surface hardening

After sinking, traditional pans are annealed by heat treatment, usually over an open fire. Mechanically pressed pans, on the other hand, undergo a nitriding heat treatment which results in a hardened surface. The sheet metal of the pan receives a sandwich-like structure with extremely hard surfaces and a relatively soft core. This structure supports note sections, which are very stable in pitch after the tuning process is completed.

3.3 The Ping, Peng, and Pong

The next step in the instrument development spelled a complete departure from the Caribbean tradition. In an attempt to stabilize the modes, contemplation of certain Indian tablas and drums suggested a central dome. Felix Rohner and his co-workers experimented with a series of instruments which are characterized by a central dome of relatively large curvature imbedded in each note section. These domes are hammered into the center of each note section over an ellipsoidal mandrel. Interestingly, except for slight frequency shifts, the mode shapes of the lowest three modes appear not to

be affected (see Figure 12). However, the higher modes become well ordered as they arrange themselves in patterns of circular symmetry around the dome. It is particularly noteworthy that the departure from cylindrical symmetry by the generally elliptical shape of the note sections removes the degeneracy which would be associated with cylindrical symmetry, causing a mode splitting, so that modes occur in pairs.

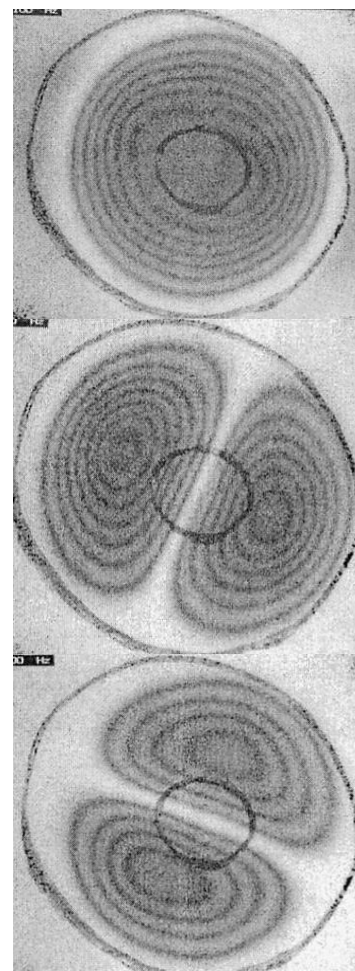

Figure 12: Ping C_4 note section
Modes (0,0) 262.2 Hz, (0,1) 519.2 Hz,
and (1,0) 773.4 Hz.

Figure 12 shows two quasi-circular lines. Both were drawn on the ping playing surface for imaging purposes, they are not a part of the normal instrument structure. The larger circle is drawn in the approximate location of the curvature change which identifies the soft boundary of the note section, the smaller circle in

the middle is drawn to identify the dome. Figures 13 & 14 illustrate higher order modes distributed around the dome with quasi-circular symmetry. Note the mode pairs, which are displaced relative to each other by roughly half of the symmetry angle as determined by the number of radial nodal lines.

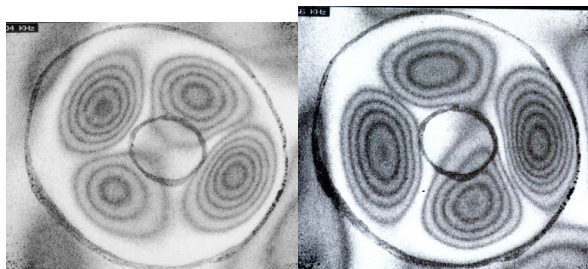

Figure 13: Two (1,1) modes of a C_4 ping note section
Left 2004 Hz; right 2066 Hz

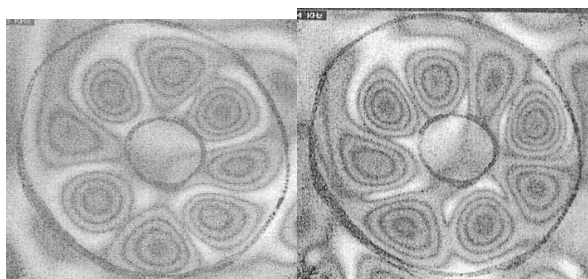

Figure 14: Two higher modes of a C_4 ping note section
Left 3725 Hz, right 3904 Hz

The examples shown are from the high pitched instrument, the ping. Corresponding mode shapes are formed in the note sections of the successively lower instruments the peng and the pong.

3.4 The Hang

The ping, the peng and the pong are performed much like the standard pan. All of these instruments are suspended between two posts of a stand, so that they are positioned at a slight angle in front of the performer, who then excites the individual note section with a small felt- or rubber-tipped mallet. The hang, on the other hand, is held on the lap and excited by the hands directly. It has a playing surface which is basically a reversed ping playing surface [3]. The performer plays on a surface of positive curvature rather than the negative curvature of the ping. This is illustrated in Figure 15. The central note resonates

with the Helmholtz mode of the body formed with bottom of the hang, which is open via a central hole.



Figure 15: The Hang

4 Conclusion

The Caribbean steelpan and its descendants have presented the physicist with a rather rich and complex challenge. Details of mode coupling mechanisms, particularly in the non-linear regime, are being studied. General modeling of the instrument in terms of coupled shell vibrations is rather complex, particularly in view of rather complicated boundary conditions. Nevertheless, experimental mode studies have assisted tuners in their efforts to enhance the quality of the sound produced by the instrument.

References

- [1] T. Rossing, U. Hansen, D. Hampton, 'Music from Oil Drums'. *Phys. Today*, Vol. 49(3) pp.24-29 (1996)
- [2] T. Rossing, U. Hansen, D. Hampton, 'Vibrational mode shapes in Caribbean steelpans. I. Tenor and double second'. *J. Acoust. Soc. Am.* Vol. 108. pp. 803-812 (2000)
- [3] T. Rossing, U. Hansen, 'The HANG: A hand played steel drum', *J. Acoust. Soc. Am.* Vol. 110 (5 pt 2) p. 2649 (abstr.) (2001)